

# **SERVICE MANUAL**

for

# **MARVEL-SCHEBLER**

**TRACTOR and INDUSTRIAL  
CARBURETERS**

**MODELS DLTX & TSX**

---

**MARVEL-SCHEBLER PRODUCTS DIV.  
BORG-WARNER CORPORATION  
DECATUR, ILL., U.S.A.**



## Principle of Operation

Marvel-Schebler Carbureters are used on thousands of tractor and industrial engines and have been designed to provide many years of trouble-free service, however, as in the case of all mechanical devices, they do in time require proper service and repairs. An understanding of their construction and how they operate as well as an understanding of their function with respect to the engine will not only avoid many false leads on the part of the service man in diagnosing so-called carbureter complaints but will create customer satisfaction and a profitable business for the progressive service shop.

To understand a carbureter it is necessary to realize that there is only one thing that a carbureter is designed to do and that is to mix fuel and air in the proper proportion so that the mixture will burn efficiently in an engine. It is the function of the engine to convert this mixture into power.

There are three major factors in an engine which control the change of fuel and air into power: 1—Compression. 2—Ignition. 3—Carburetion.

Carburetion has been listed last because it is absolutely necessary for the engine to have good compression and good ignition before it can have good carburetion.

When the average person thinks of "carburetion" they immediately think of the carbureter as a unit. Carburetion is the combined function of the carbureter, manifold, valves, piston and rings, combustion chamber, and cam shaft.

It can be readily seen that "carburetion" is a far deeper subject than consideration of the carbureter alone, and expecting the carbureter to cure faulty ignition, compression, valves, etc. will only result in wasted time and effort on the part of the service man and added expense to the customer.

It must be remembered that the function of the carbureter does not extend beyond delivering the proper mixture of fuel and air to the manifold and the other factors which effect

power and economy cannot be changed or corrected by the carbureter. Inability to understand all the factors that effect engine operation is the reason many service mechanics change from factory standards and attempt to improve on the engine set-up by their own methods or "standards". All that any service mechanic should ever try to do is to make the particular engine he is working on as good as the manufacturer intended it to be, but he can make it a lot worse. Far too many engines are running below their standard of performance in service today.

For the carbureter to accomplish its function it must be able to vary the mixture strength dependent upon the engine demands. It must supply a mixture strength that will allow the engine to give maximum horsepower, whenever the throttle is fully opened, while at part throttle conditions it must lean out the mixture so that maximum economy can be obtained. In addition it must have flexibility throughout the entire range of operating speeds, from idle and part throttle to full power wide open throttle position. The carbureter must also have an accelerating "well" with enough fuel capacity to start handling sudden maximum loads. In other words the carbureter not only varies the volume of fuel and air that enters the engine but also varies the amount of fuel that goes in with a given amount of air, in order to produce the proper mixture proportion for any condition under which the engine is operating at any time.

In order to understand the function and operation of the Marvel-Schebler Tractor and Industrial Carbureters it is well to consider the systems that make up each carbureter. These systems are: The Float System, The Idle System, The Power Fuel Feed System, The Back Suction Economizer System, and The Choke System.

A thorough knowledge of each system will help the service mechanic to quickly locate and correct legitimate carbureter complaints as well as to inspect, repair, and put back to standard any carbureter that requires an overhaul.

## Float System

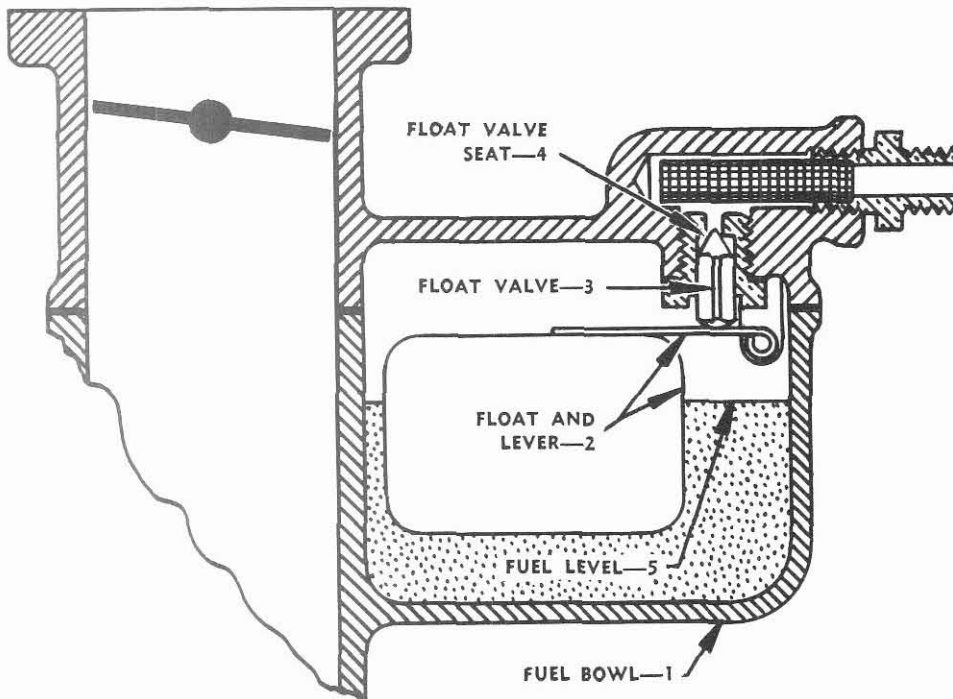

The float system controls the level and supply of gasoline in the fuel bowl throughout the operating range of the engine.

When the fuel bowl (1) is empty the float and lever (2) and float valve (3) drop and fuel under pressure from the fuel pump (or gravity feed) is forced through the float valve seat (4) around the float valve (3) and into the fuel bowl (1). As the fuel in the bowl approaches the correct operating level it raises the float and lever (2) with enough force to raise the float valve and cut off the flow of fuel into the bowl. As fuel feeds through the carburetor jets into the engine the fuel level (5) drops, allowing additional fuel to enter the fuel bowl.

Under actual operating conditions the fuel level (5) and float and lever (2) automatically position themselves so that the inward flow of gasoline to the carburetor is equal to the outward flow of gasoline to the engine.

As can readily be seen the float system under the most favorable of operating conditions is subjected to a certain amount of wear. Under severe conditions or conditions that result in excessive vibrations being transmitted to the carburetor, float valve and float valve seat wear is accelerated.

It should be an established policy that whenever the carburetor is disassembled for whatever cause the service man make following checks:

1. Examine float valve for any signs of wear. If it is not absolutely true or is grooved and hasn't a perfect taper, a new float valve and also a new float valve seat must be used. These float valves and seats are supplied in matched sets and are tested at the factory for leaks. Always use a new float valve seat gasket to make sure of a perfect seal.
2. Examine float for any signs of failure. To test metal float submerge float in pan of hot water and if air bubbles are observed replace with new float.  
  
Examine cork float for bare places or cracks in coating. If either are found, or if float shows evidence of having been soggy, replace with new one. (Do not attempt to recover float with shellac or varnish.)
3. Set float height to the proper specification for the particular model carburetor being serviced. Make certain that the entire assembly works free and that there is no binding.
4. Wash fuel strainer assembly in gasoline and clean screen with air under pressure. If the screen, or the threads on the strainer are not in good condition, install a new assembly. When re-installing fuel strainer assembly always use a new strainer gasket if a gasket is used to obtain a seal.

It has been proven, with few exceptions, that with a float system in good order, carburetor flooding only occurs when dirt or foreign matter becomes lodged between the float valve (3) and float valve seat (4).

## The Idle System

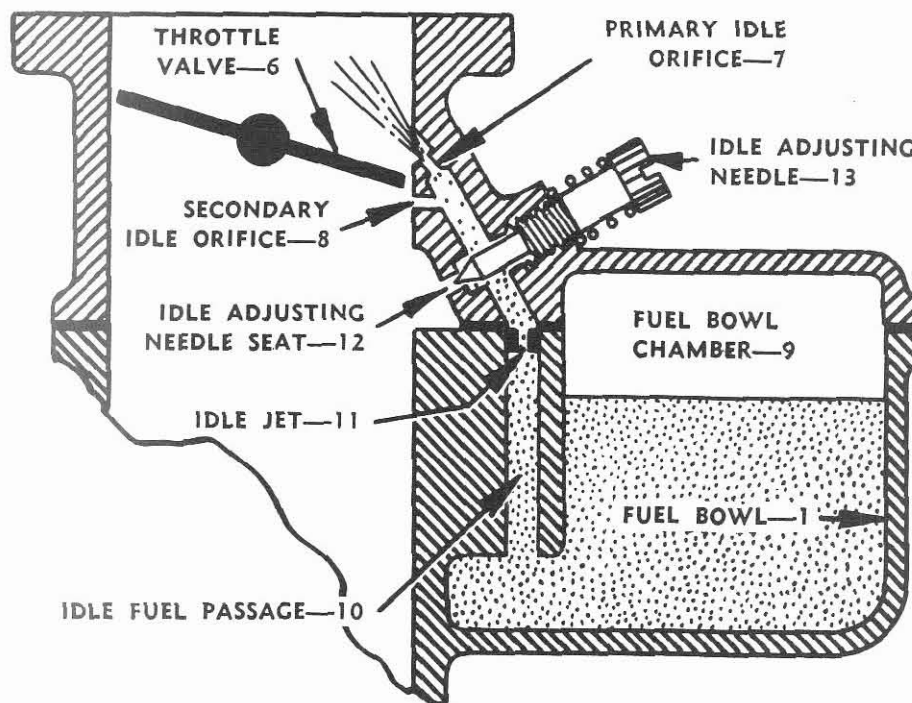

The idle system controls the flow of fuel at idle speed and at slow speeds until the throttle is opened wide enough to allow the power fuel feed system to function.

When the throttle valve (6) is in the idle position the edge of the valve is between the primary idle orifice (7) and the secondary idle orifice (8). With the valve in this position the air pressure (manifold vacuum) at the primary idle orifice (7) is lower than the air pressure in the fuel bowl chamber (9) and fuel is forced from the fuel bowl (1) into the idle fuel passage (10). As the fuel travels through the idle fuel passage (10) it passes through the metering orifice of the idle jet (11) to the point where it is combined with air entering through the idle adjusting needle seat (12). The mixing of air with gasoline helps to atomize the fuel and this process is repeated at the secondary idle orifice (8) as the fuel travels through the idle fuel passage (10). As this rich mixture of fuel and air emerges from the primary idle orifice (7) it is reduced to correct proportions by the air which passes around

the throttle valve (6) since this valve must be slightly open to permit the engine to idle. The resultant mixture is correct for operating engine at idle speed, provided the idle adjusting needle (13) is properly adjusted.

As the throttle valve (6) is slowly opened from the slow idle position it gradually subjects the secondary idle orifice (8) to intake manifold vacuum, and the secondary idle orifice (8) no longer bleeds air to the idle fuel passage (10) but feeds an additional quantity of fuel into

the engine. This is proper since the throttle valve is now open wider and will admit a greater amount of air to blend with this additional fuel to maintain the correct proportions of fuel and air for the engine.

As the throttle valve (6) is opened still wider, the idle fuel delivery begins to fade out, however, the throttle valve at this point is far enough open for the power fuel feed system to begin functioning.

The idle system as described above is the most positive and satisfactory of idle systems, as it is working under very high suction and the mixture flows through the small passages and orifices at very high velocities. It is necessary to bear in mind, however, that there are times when these small holes may become plugged with particles of dirt or foreign matter and will require cleaning. At such times the passages, jets, and small drilled holes should only be cleaned with a cleaning fluid such as gasoline and air under pressure. Never use drills or wires as a change in size of these small openings will change the entire calibration of the carbureter.

## Power Fuel Feed System

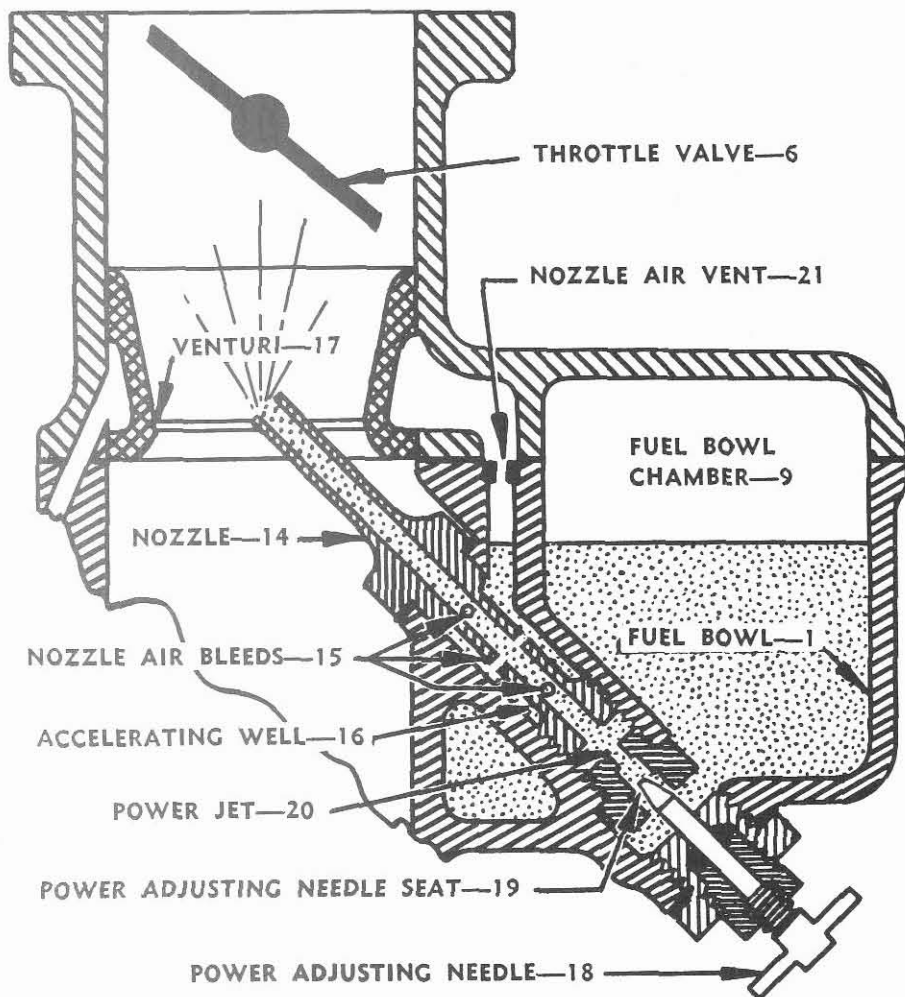

With the throttle valve (6) in slow or just off slow idle position, fuel rises up through the nozzle (14) and out the nozzle air bleeds (15) to fill the accelerating well (16) to approximately the height of the fuel level in the fuel bowl (1).

As the engine speed is increased from the slow idle position the air flow through the venturi (17) is gradually increased, and, as the idle system begins to diminish, the velocity through the venturi (17) is high enough to create a pressure at the tip of the nozzle (14) slightly less than the pressure in the fuel bowl chamber (9) and the accelerating well (16). Fuel, therefore, feeds from the fuel bowl (1) through the opening between the power (load) adjusting needle (18) and the power adjusting needle seat (19), through the power jet (20) and out the nozzle (14) to be discharged into the air stream at the

venturi (17). At the same time, the fuel that is stored in the accelerating well (16) is also forced through the nozzle air bleeds (15) into the nozzle (14). But, because the size of the power jet (20) and the position of the power adjusting needle (18) restrict the amount of fuel which can enter the nozzle (14), the fuel in the accelerating well (16) will soon be exhausted and air will then enter through the nozzle air bleeds (15) to mix with the fuel passing through the nozzle (14). The amount of air that can enter into the nozzle (14) is limited by the size of the nozzle air vent (21).

The result of air bleeding into the nozzle (14) is, to help atomize or break up the fuel into finer particles, to regulate the quantity and the rate of discharge

of the fuel fed from the accelerating well (16), during acceleration, and to provide the correct mixture proportions for full throttle operation.

As the throttle valve is opened toward the wide open position the velocity through the venturi (17) continues to increase, lowering the air pressure at the nozzle (14) and resulting in additional fuel being supplied to the engine as the speed is increased.

When the throttle valve (6) is opened suddenly from slow or just off slow idle position, the fuel stored in the accelerating well (16) is forced out through the nozzle air bleeds (15) very rapidly and serves to provide the extra richness required by the engine to meet the sudden load. When the throttle valve (6) is closed fuel again fills the accelerating well (16), ready for the next acceleration.



## Back Suction Economizer System

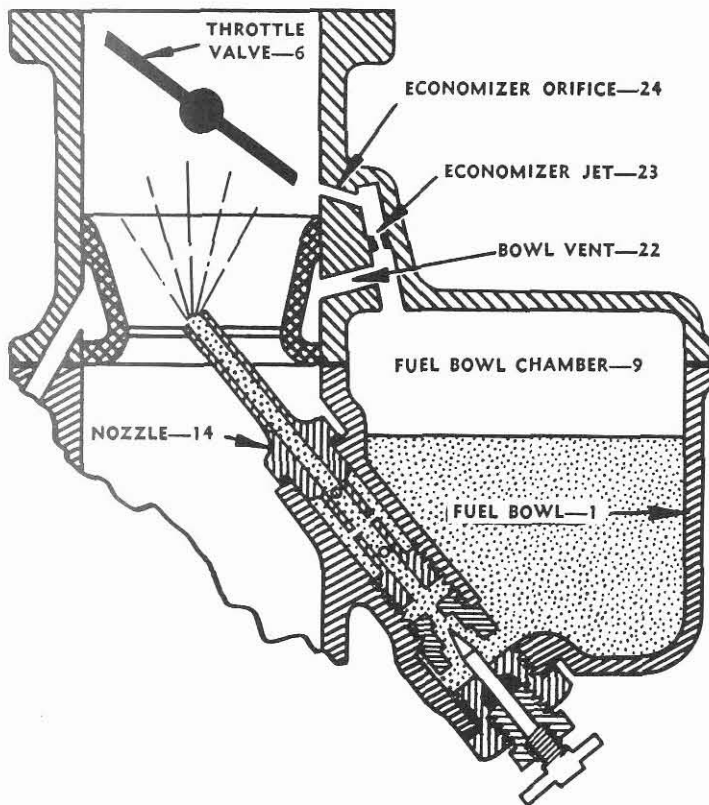

The amount of fuel supplied to an engine is controlled by the size of the power jet, the position of the power adjusting needle, and the difference in air pressure between the fuel bowl chamber and the venturi. However, in many engines the mixture must be leaned out additionally during part throttle operation to obtain maximum economy. To provide this leaner mixture Marvel-Schebler Tractor and Industrial Carbureters make use of the "Back Suction Economizer System. With this method of metering fuel, the air pressure in the fuel bowl chamber is regulated and controlled according to load conditions by a combination of bowl vent and economizer passages communicating with the throttle bore of the carbureter. Through regulations of the air pressure in the fuel bowl chamber the fuel flow through the carbureter can be controlled to provide the proper mixture proportions for the engine.

All the air that enters the fuel bowl chamber (9) must first pass through the air cleaner and the bowl vent (22). The size of the bowl vent (22) controls or limits the amount of air that can enter the fuel bowl chamber (9). The

amount of air that is drawn out of the fuel bowl chamber (9) is controlled by the size of the economizer jet (23), the economizer orifice (24) and the position of the throttle valve (6) as its position determines the manifold vacuum or suction on the economizer orifice (24). As the throttle valve (6) is opened from the fast idle position the economizer orifice (24) is gradually exposed to manifold suction, and air flows from the fuel bowl chamber (9), through the economizer jet (23) and out the economizer orifice (24). This air must be replaced by air entering through the bowl vent (22) but as the size of the bowl vent (22) restricts the amount of air that can enter, the resultant pressure in the fuel bowl chamber (9) will be lowered, reducing the difference in air pressure between the nozzle (14) and the fuel bowl chamber (9). The flow of fuel will therefore be retarded so that the exact economy mixture ratio will be delivered to the engine at this particular throttle opening. Opening the throttle valve (6) further exposes the entire economizer orifice (24) to manifold suction, resulting in additional air being removed from the fuel bowl chamber (9), again leaning out the mixture ratio to the correct proportions for this new throttle position. After the economizer orifice (24) is fully exposed to manifold suction the amount of air that is drawn out of the fuel bowl chamber (9) is controlled by the manifold vacuum or suction at any given throttle valve (6) position and as this suction decreases as the throttle approaches wide open position, less air is drawn out of the fuel bowl chamber and additional fuel flows to the engine to provide the extra richness required for operation at heavy loads where maximum horsepower is necessary.

The "Back Suction Economizer System" assures the proper metering of fuel to the engine throughout the service life of the carbureter as there are no moving parts to wear out or adjustments to get out of order. It is essential, however, that the system remain free of dirt and foreign matter because any foreign substance in the system will restrict the flow of air thereby creating improper pressures in the fuel bowl chamber and resulting improper fuel delivery to the engine.

## Choke System

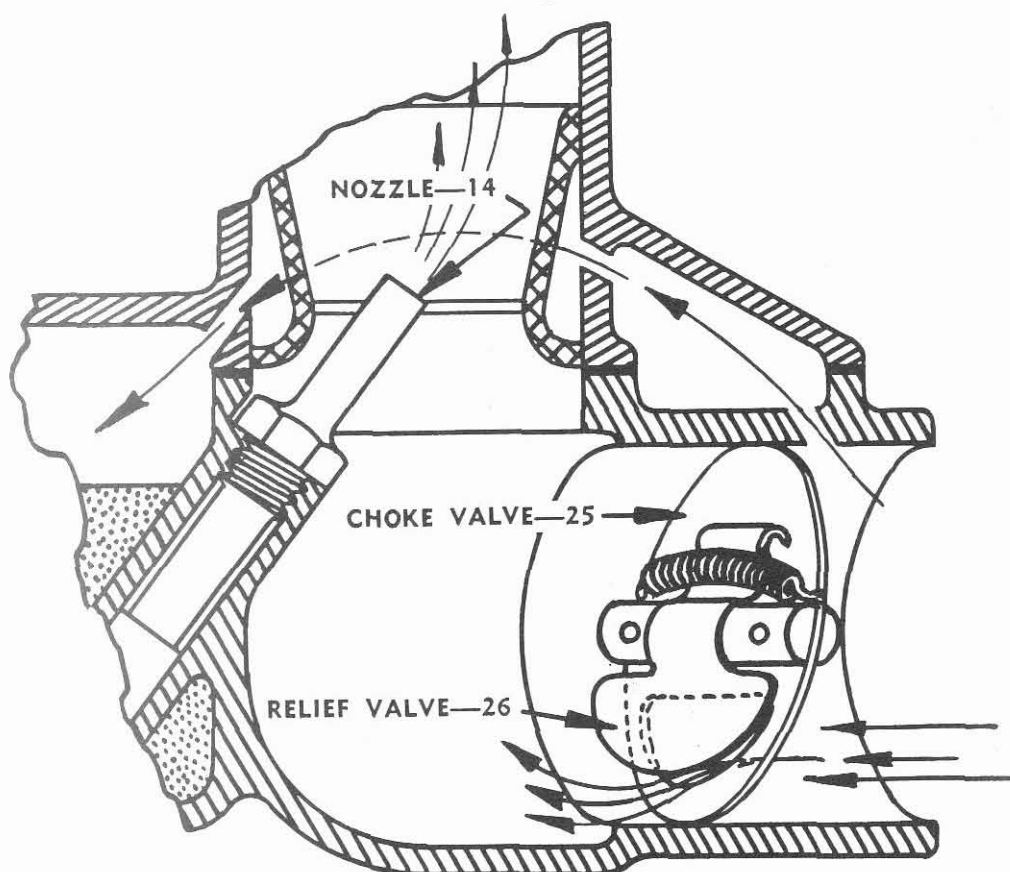

The choke system is used during cold starting and the warm-up period. Under these cold conditions it is necessary to supply an additional rich mixture of fuel and air, as only the "light ends" or more volatile portions of the fuel will vaporize with the manifold and air temperatures at these cold conditions. Consequently it is necessary that a large quantity of fuel be available so that there will be enough "light ends," to combine with the air to form a combustible mixture for starting the engine.

The function of the choke valve (25) is to restrict the amount of air that can enter the carbureter and to increase the suction on the nozzle (14) so that additional fuel will be drawn into the manifold. As soon as the engine fires and runs the rich mixture must be rapidly reduced to prevent stalling. This change in mixture is accomplished by the operator positioning the choke valve to provide the proper mixture. However, a few degrees movement of the choke valve (25) will make a big change in the mixture strength and to help reduce the sensitivity of the choke

valve (25) position use is made of a spring loaded relief valve (26) in many applications. This valve opens automatically with engine speed and load and eliminates a great deal of manipulation of the choke on the part of the operator.

When the engine has obtained normal operating temperature the choke valve (25) must be fully opened to assure maximum power and economy. In addition, extended use of the choke results in more gasoline being supplied to the engine than can be burned. A large percentage of the unburned gasoline is lost through the exhaust system. The remainder of the raw gasoline is forced between the pistons and cylinder walls, washing away the protective oil film and increasing engine wear, and enters the crankcase where it dilutes the engine oil.

Any adjustments that are necessary on the carbureter should never be attempted until the engine has obtained its normal operating temperature and the choke valve (25) has been placed in the wide open position.



## Model TSX Carbureter

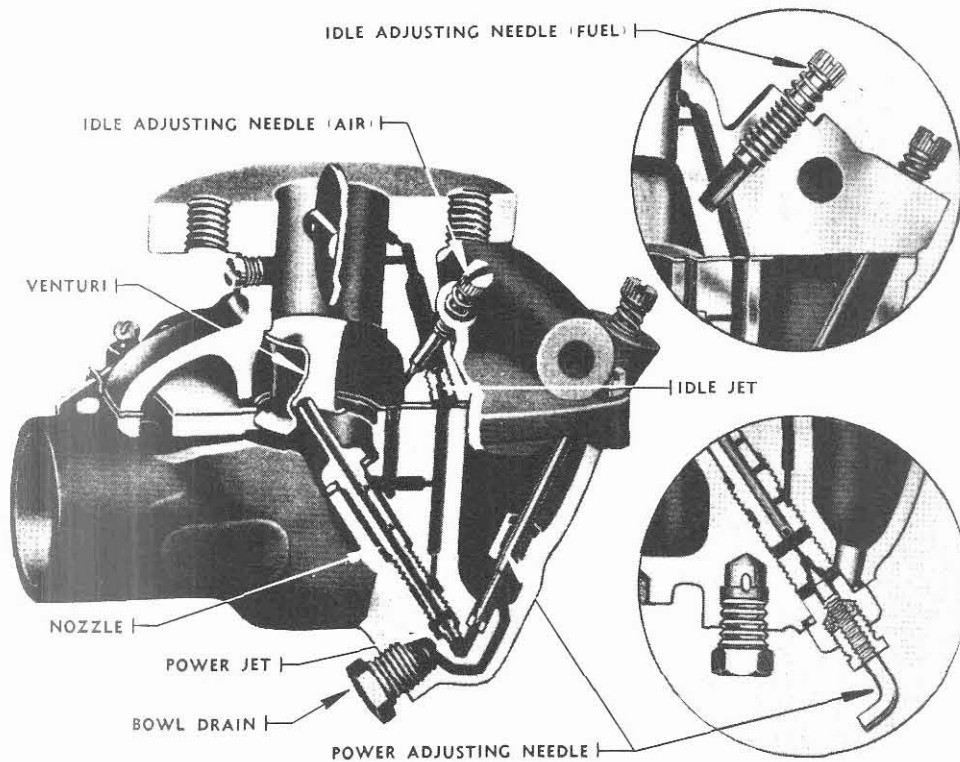

Fig. 1—Idle and Power Fuel Feed Systems

The Marvel-Schebler Model TSX Carbureter is manufactured in three S.A.E. nominal sizes:  $\frac{7}{8}$  inch, 1 inch, and  $1\frac{1}{4}$  inch. In addition to these variations in size, there are also variations necessitated by the specific requirement of the engines on which the carbureters are used. Many engines, for instance, require special throttle and choke operating levers, and for purpose of calibration, they may have different size jets, nozzles, venturii, etc. For this reason when ordering parts, refer to the individual carbureter service parts list for the engine on which the carbureter is installed.

The Model TSX Carbureter consists of only two major castings:

1. The throttle body casting which forms the cover for the fuel bowl.
2. The fuel bowl casting which contains the air inlet.

Cast iron material is used for ruggedness. It will be noticed (Figure 1) that all passages, whenever possible, are drilled from the top face of the fuel bowl casting to prevent any fuel leaks to the outside of the carbureter, because of shrunken gaskets or defec-

tive hole plugs, and also to prevent vapor lock or "percolation" of the fuel when the carbureter is operated under extremely hot conditions, resulting in hard starting or erratic engine operation.

The Model TSX carbureter is completely sealed against dust or dirt. All air entering the fuel bowl of the carbureter must first pass through the air cleaner. The throttle shaft bearings and choke shaft bearings are sealed to eliminate dust and dirt entering at these points.

The back suction economizer system (Figure 2) is provided with a removable economizer jet. The size of this jet has been carefully established by engineering tests to provide the exact fuel requirements

for maximum economy at part throttle operation. Always use the economizer jet specified in the individual carbureter service parts list to assure proper engine operation. On some carbu-

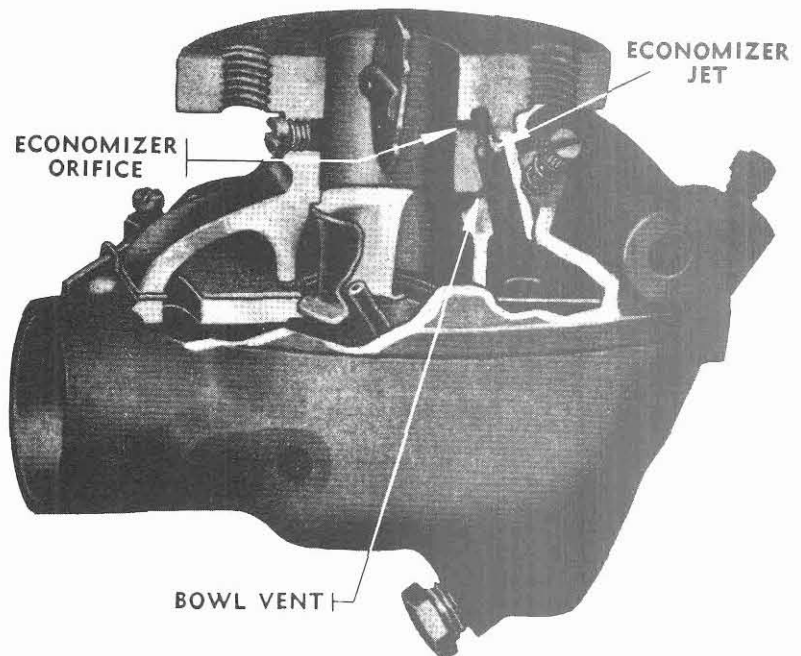

Fig. 2—Back Suction Economizer System

## Model TSX Carbureter

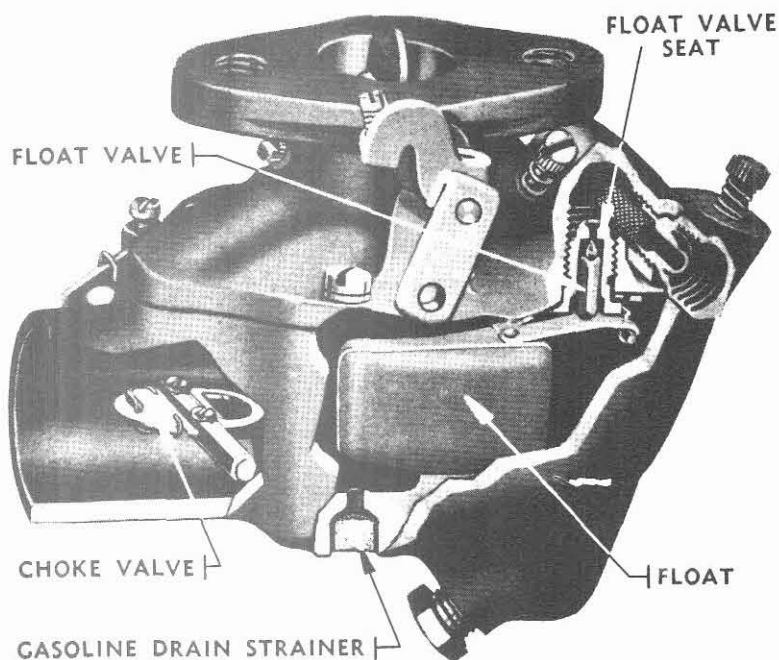

Fig. 3—Float and Choke Systems

reter models the proper fuel requirements are established without the use of an economizer jet and the fixed economizer orifice machined in the carbureter throttle body regulates the fuel supplied to the engine. In addition, there are engine and carbureter combinations that do not require the back suction economizer system. In these carbureters the economizer orifice has not been machined in the throttle body casting.

To provide additional economy, in addition to the back suction economizer system, some carbureters are provided with two adjusting needles, the low speed or idle adjusting needle, and the power or load adjusting needle. However, the power adjusting needle is not always required and for applications of this nature the fixed jet type carbureter is used in which the power jet controls the amount of fuel that is supplied to the engine.

There are two variations in carbureters having the power adjusting needle, commonly called the adjustable jet type carbureter. In Figure 1 is shown these two arrangements. The adjustment of either type is accomplished in the same manner.

A large percentage of the Model TSX Carbureters are provided with an idle adjusting needle which alters the fuel and air proportions of the mixture which enters the carbureter bore from the idle passage (Figure 1). This is known as an

air adjusting idle needle. The upper inset in Figure 1 shows an idle adjusting needle which alters the amount of fuel and air mixture which enters the carbureter bore from the idle passage. This is commonly known as a fuel adjusting idle needle. It is important to remember in setting the idle mixture the air adjusting idle needle must be turned in, or clockwise, to enrich the idle mixture, and the fuel adjusting idle needle must be turned out, or counter-clockwise to enrich the idle mixture.

A dual float mechanism (Figure 3) is used in a fuel bowl that almost completely surrounds the nozzle. This design and construction is such that the tractor, or engine, can be operated at any angle up to 45 degrees without seriously affecting the fuel and air ratio and without flooding because the mean level at the nozzle tip is practically constant at any angle of operation.

Some carbureters are equipped with a spring-loaded governor control lever to permit manual closing of the throttle to an idle position for engines equipped with certain type governors. An example of this type lever is shown in Figure 4, however, there are other variations of this type dependent upon the particular application.

While there are many variations produced by combining the different types and sizes into a specific application, all Model TSX carbureters incorporate the same engineering principles and are alike from a functional standpoint.

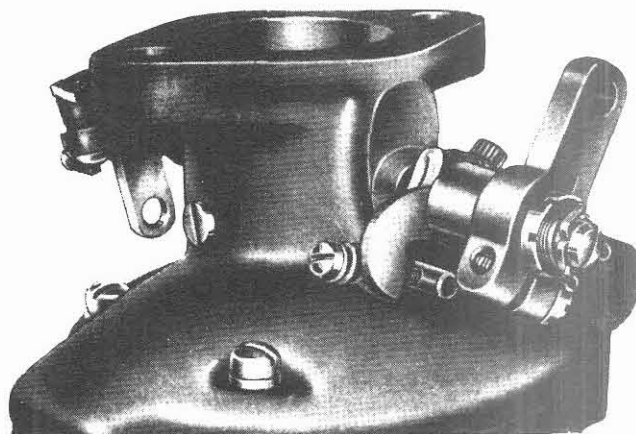
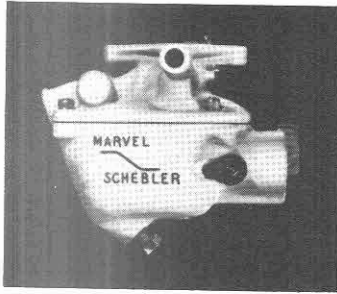
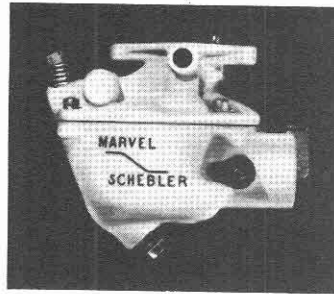

Fig. 4—Spring-Loaded Governor Lever

## Service Instructions for Model TSX Carburetors



Type A—Fixed Jet



Type B—Adjustable Jet

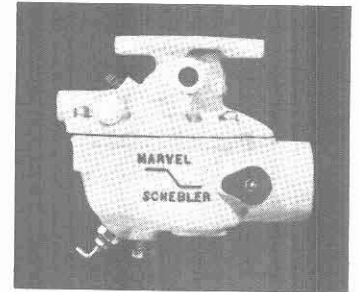

Type C—Adjustable Jet

The following procedure for service of all Model TSX Carburetors is for a complete overhaul. After removing carburetor from engine wash thoroughly with cleaning fluid such as gasoline to permit examination of external parts for damage. For type carburetor being serviced see illustrations above. Instructions apply to all types unless specified otherwise.

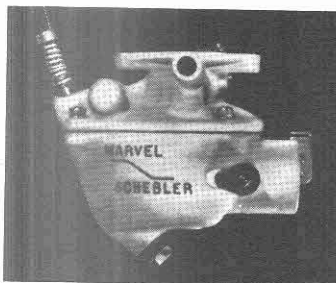

- 1—  
**Remove Power Adjusting Needle Assembly.**  
Type B.

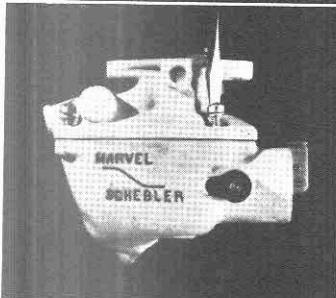

- 2—  
**Remove Bowl Cover Screws and Lock Washers**  
Separate Castings.

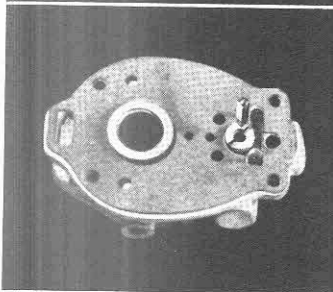

- 3—  
**Remove Float Valve, Bowl Gasket, and Venturi.**  
If Valve is grooved or damaged, replace Valve and Float Valve Seat.

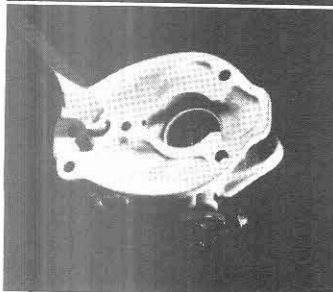

- 4—  
**Remove Float Valve Seat and Gasket.**

- 5—  
**Remove Economizer Jet.**  
NOTE. Not required in all carburetors. Check service parts list or repair kit of carburetor being serviced.

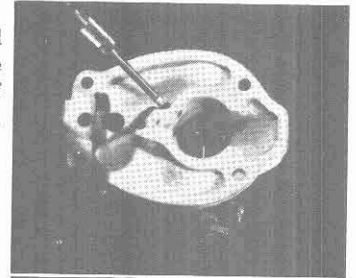

- 6—  
**Remove Idle Jet**  
NOTE. Not required in all carburetors. Check service parts list or repair kit of carburetor being serviced.

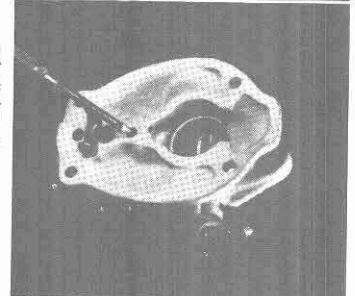

- 7—  
**Removing Idle Adjusting Needle and Spring**  
Replace with new Needle if grooved or damaged

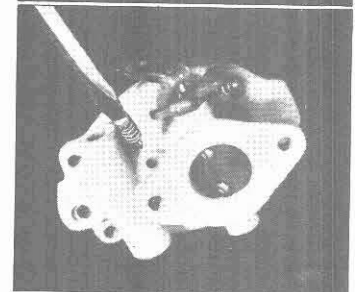

- 8—  
**Remove Throttle Valve Screws, Valve, and Throttle Shaft and Lever Assembly**  
Replace with new shaft and lever assembly if excessive looseness between shaft and throttle body.

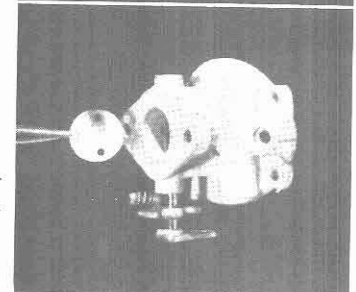

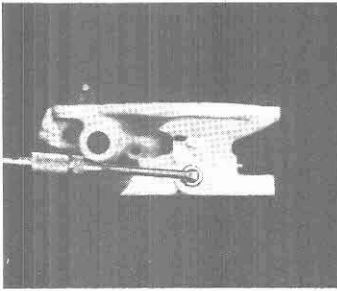

9—  
**Remove Throttle Shaft  
Packing Retainer  
and Packing**

Force out Retainer  
with small screwdriver  
or punch

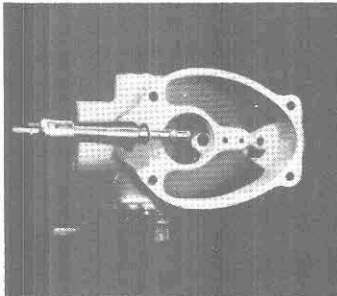

10—  
**Remove Main Nozzle  
and Gasket.**

Type A  
Type B

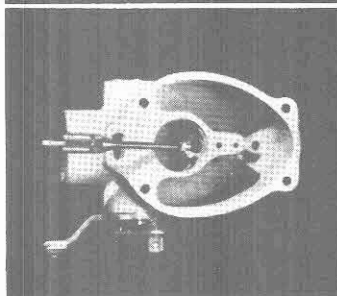

11—  
**Remove Power Jet.**

Type A  
Type B

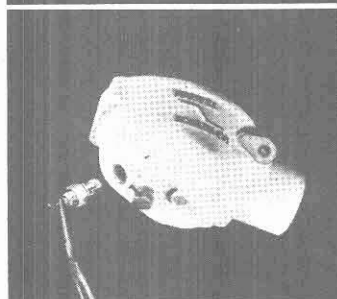

12—  
**Remove Power Adjusting  
Needle Assembly.**

Type C

Carburetors not having  
adjustable needle remove  
power jet.

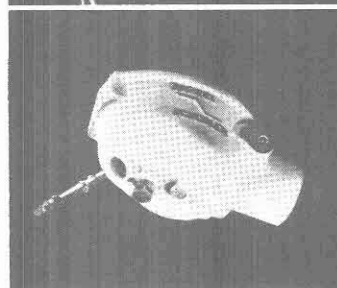

13—  
**Remove Main Nozzle  
and Gasket.**

Type C

14—  
**Remove Retainer Plug  
and Gasoline Drain  
Strainer.**

Strainer can only be re-  
placed on carburetors hav-  
ing a curled hair or felt  
type strainer. Only re-  
place when impossible to  
clean with gasoline and  
compressed air. Porous  
metal type strainer can-  
not be replaced. Clean  
only.

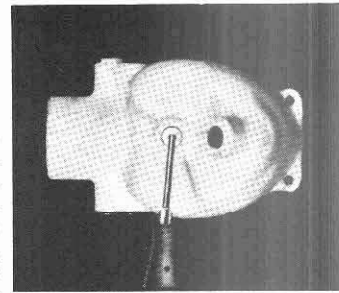

15—  
**Remove Choke Valve  
Screws, Valve, Choke  
Shaft & Lever Assembly,  
Choke Return Spring,  
and Choke Bracket.**

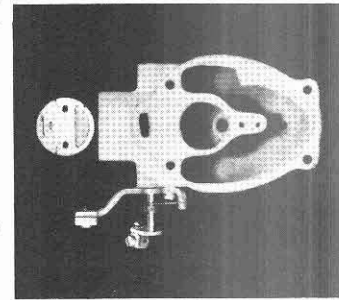

16—  
**Remove Choke Shaft  
Packing Retainer  
and Packing.**

Force out retainer with  
small screwdriver  
or punch.

**\*ASSEMBLE**

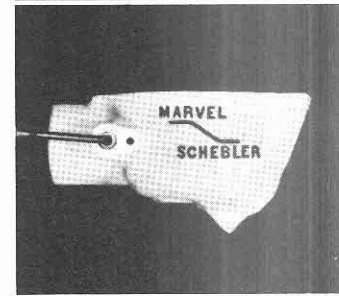

17—  
**Install Throttle Shaft  
Packing and Retainer.**

Assemble new retainer  
and packing on throttle  
shaft. Insert shaft in  
carburetor and tap lightly  
until retainer is flush with  
casting face.

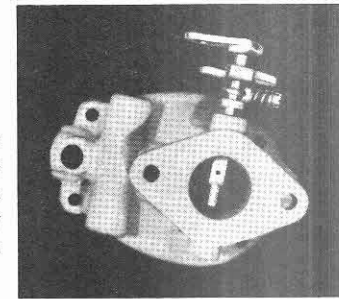

18—  
**Install Throttle Valve  
and Screws.**

Install valve with angle  
identification mark facing  
flange face of carburetor.  
Tap valve lightly to cen-  
ter in throttle bore. Tight-  
en screws securely.

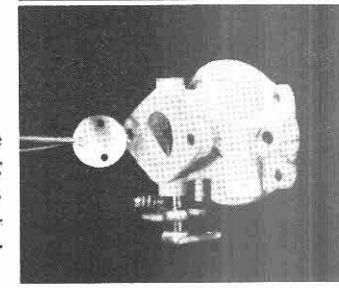

**\*Before assembling carburetor, clean castings, channels, and parts with carburetor cleaning fluid and air under pressure. Make certain all small holes and channels are open and free from carbon and dirt. Do not use wire or small drills to clean out small holes as a slight change in size of these holes will affect the carburetor operation. To assure a successful overhaul always replace all worn or damaged parts and any parts that are questionable. Always use all new gaskets.**



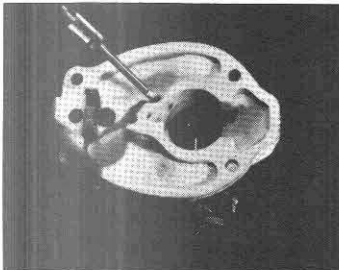

19—  
Install Economizer Jet.

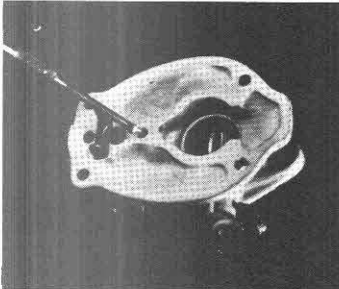

20—  
Install Idle Jet.

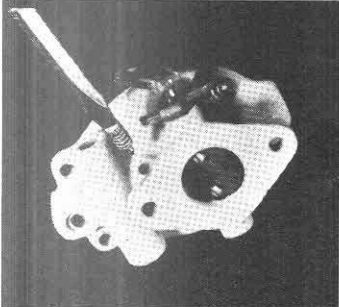

21—  
Install Idle Adjusting Needle and Spring.

Set approximately one turn from seat for preliminary setting.

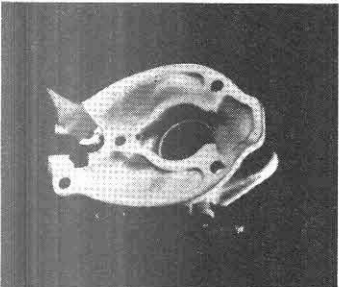

22—  
Install Float Valve Seat and Gasket.  
Use new Float Valve and Seat Assembly.

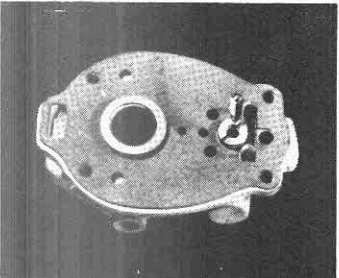

23—  
Assemble Bowl Cover Gasket and Venturi in Casting.

Install float valve.

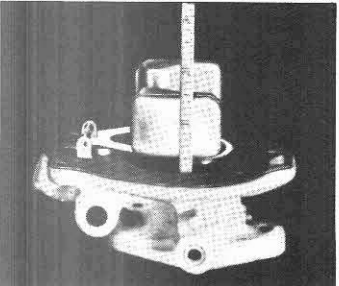

24—  
Install Float and Lever Assembly and Float Lever Pin.

Set floats  $\frac{1}{4}$ " from gasket face to nearest edge of float, keeping edge of float parallel with gasket. Adjust by using bending tool #M-8.

25—  
Install Choke Shaft Packing Retainer and Packing.

Install retainer as shown in illustrations below.  
Note: On some carburetor models the packing is retained by choke bracket in place of packing retainer.

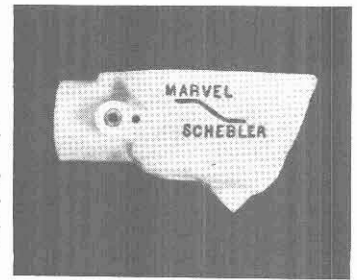

25A—  
On carburetors counter-bored  $\frac{1}{8}$ " to  $\frac{5}{32}$ " deep install retainer with cup facing towards casting. Tap lightly until flush with casting face.

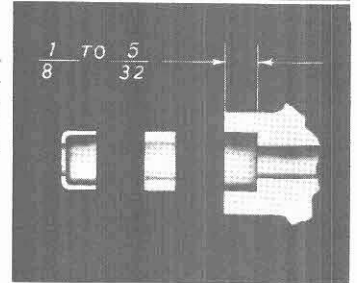

25B—  
On carburetors counter-bored  $\frac{1}{32}$ " to  $\frac{1}{4}$ " deep install retainer with cup facing away from casting. Tap lightly until flush with casting face.

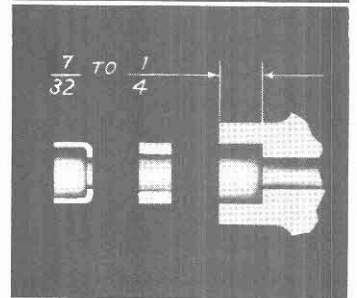

26—  
Install Choke Bracket, Choke Return Spring, Choke Shaft and Lever Assembly, Valve, and Screws.

Center valve in casting before tightening screws.

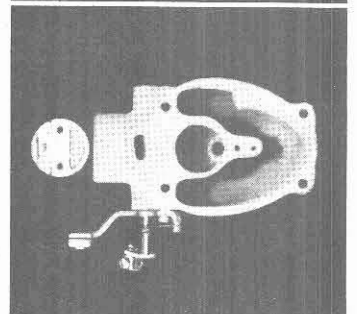

27—  
Install Power Jet.

Type A  
Type B

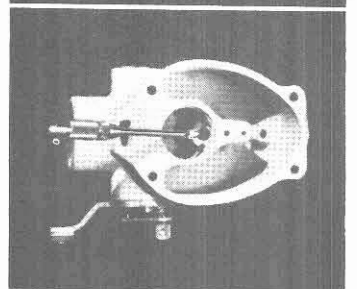

28—  
Install Main Nozzle and Gasket.

Type A  
Type B  
Use new gasket.

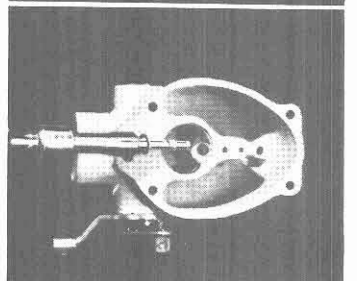



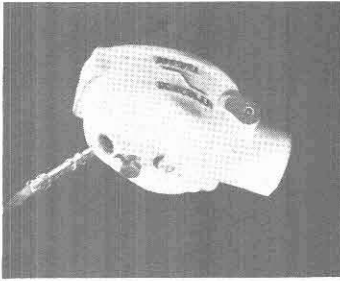

29—  
**Install Main Nozzle and Gasket.**  
Type C  
Use new gasket.

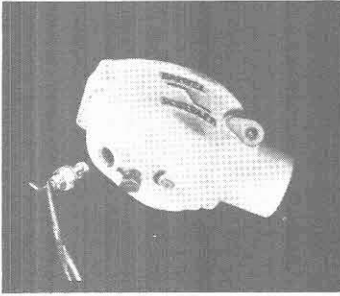

30—  
**Install Power Adjusting Needle Assembly.**  
Type C  
Use new gasket.  
Set approximately one turn from seat for preliminary setting.

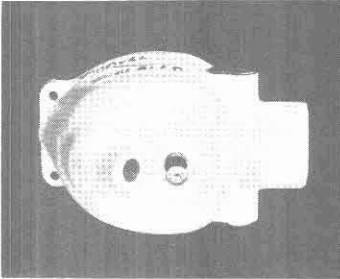

31—  
**Install Gasoline Drain Strainer & Retainer Plug.**  
Stake retainer plug in place with center punch to insure secure locking.

32—  
**Assemble Castings.**  
Invert throttle body and lower fuel bowl over floats taking precaution that venturi guides bodies into position.

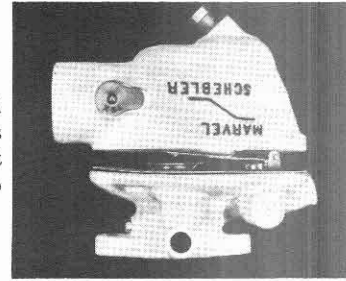

33—  
**Install Bowl Cover Screws and Lock Washers.**  
Tighten screws gradually until all are tight.

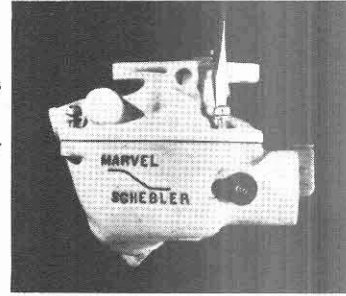

34—  
**Install Power Adjusting Needle Assembly.**  
Type A  
Set approximately one turn from seat for preliminary setting.

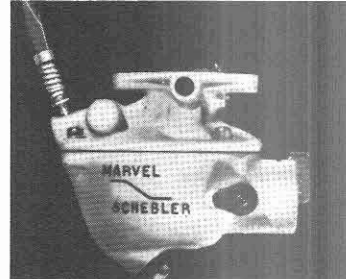

## Adjustment Instructions

### PRELIMINARY ADJUSTMENTS

Set throttle stop screw so that throttle valve is open slightly. Make certain that fuel supply to carburetor is open. Close choke valve. Start engine and partially release choke. After the engine has been run sufficiently to bring up to operating temperature throughout, see that choke is returned to wide open position.

### LOW SPEED OR IDLE ADJUSTMENT

Set throttle or governor control lever in slow idle position and adjust throttle stop screw for the correct engine idle speed. (On a new, stiff engine this speed must be slightly higher than required for a thoroughly run-in engine.) Turn idle adjusting needle\* until engine begins to falter or roll from richness, then turn needle in the opposite direction until the engine runs smoothly.

NOTE: It is better that this adjustment be slightly too rich than too lean.

NOTE: Carburetors TSX-107, TSX-330, TSX-339, TSX-355, TSX-385 and TSX-398 use the fuel adjusting type idle needle. All other Model TSX Carburetors use the air adjusting type idle needle.

### \*IDLE ADJUSTING NEEDLE—AIR ADJUSTING

To richen the idle mixture turn the idle adjusting needle to the right or clockwise.

### \*IDLE ADJUSTING NEEDLE—FUEL ADJUSTING

To richen the idle mixture turn the idle adjusting needle to the left or counter-clockwise.

### POWER OR LOAD ADJUSTMENT (TYPE B, TYPE C)

With the engine running at governed speed under load, turn power adjusting needle to the right, or clockwise, a little at a time until the power drops appreciably. Then turn the needle to the left, or counter-clockwise, until the engine picks up power and runs smoothly. This will give an economical part throttle mixture, and, due to the economizer action, the proper power mixture for full throttle operation. Due to variations in temperature or fuels it may be necessary to richen up this mixture by backing out the power adjusting needle, a small amount at a time until good acceleration is obtained.

## Model DLTX Carbureter

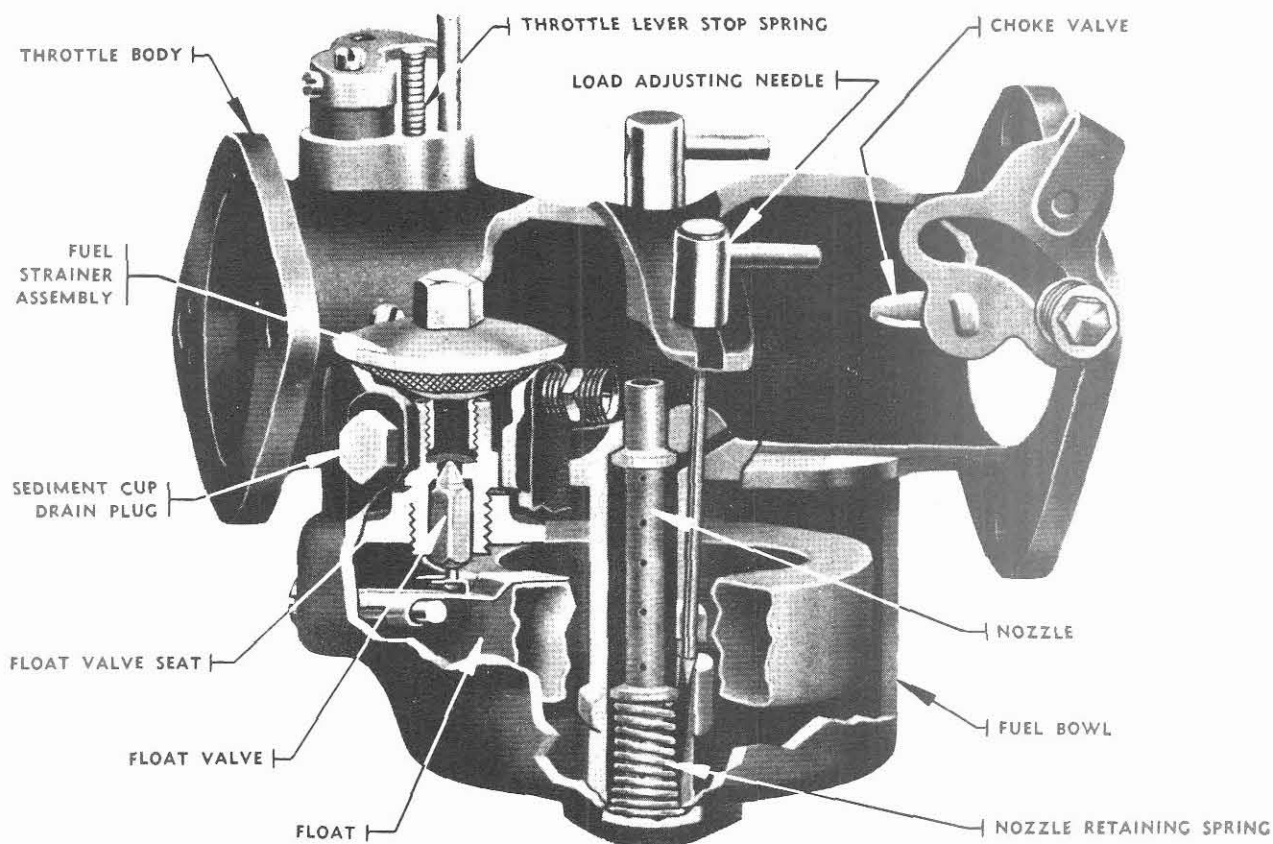

Fig. 1—Choke, Float and Power Fuel Feed Systems

The Marvel-Schebler Model DLTX Carbureter is a horizontal type carbureter used on John Deere tractors. To meet the specific engine requirements of the individual tractor on which the carbureter is installed requires different size jets, nozzles, venturi, throttle and choke operating levers, etc. For this reason, when ordering parts, always refer to the individual carbureter service parts list for the engine on which the carbureter is installed.

The Model DLTX Carbureter consists of two castings:

1. The throttle body casting which contains the air inlet.
2. The fuel bowl casting.

The throttle body casting contains, in addition to the throttle assembly, a venturi machined in the casting and the choke assembly. Cast iron material is used for ruggedness. All passages, whenever possible, are drilled within the cast-

ing to prevent any fuel leaks to the outside of the carbureter because of shrunken gaskets or defective hole plugs.

The Model DLTX Carbureter is completely sealed against dust or dirt. All air entering the fuel bowl of the carbureter must first pass through the air cleaner. The throttle shaft bearings and the choke shaft bearings are sealed to eliminate dust and dirt entering at these points. New throttle shaft bushings can be installed when the bearings have become worn.

The float mechanism is contained in a cast iron fuel bowl (Figure 1) on all DLTX models with the exception of Model DLTX-26 and Model DLTX-46. In these two carbureters the float assembly is retained by the throttle body casting surrounded by a stamped metal fuel bowl.

All models have a fuel strainer to prevent dirt and foreign substance from entering the fuel

## Model DLTX Carbureter

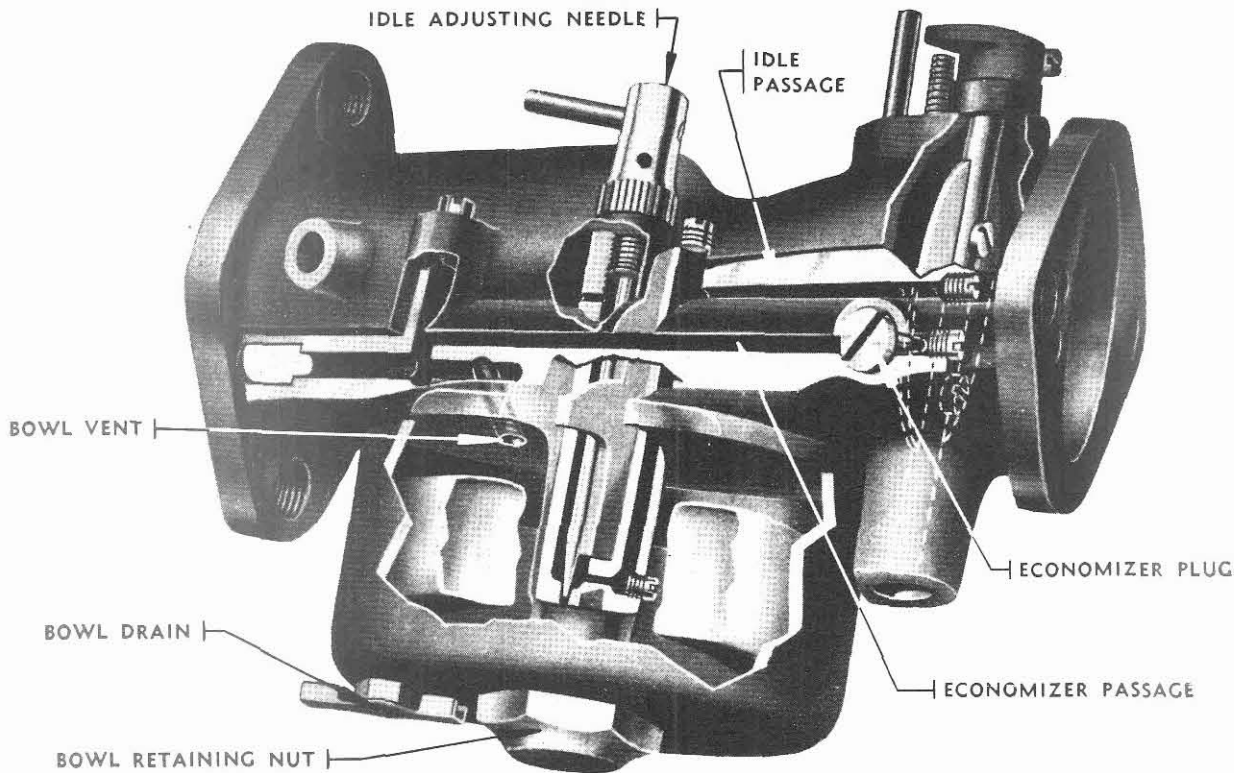

Fig. 2—Idle and Back Suction Economizer Systems

bowl. To service the fuel strainer in the cast iron fuel bowl, first remove the sediment cup drain plug (Figure 1) to permit any dirt to drain off. Then remove the fuel strainer assembly and clean with gasoline and air under pressure. Flush sediment cup by turning on fuel supply valve using a small brush to wash out any remaining dirt in cup. Be careful not to damage or remove composition gasket on fuel strainer assembly. Always replace any damaged gasket.

A calibrated economizer plug (Figure 2) is used in the back suction economizer system to regulate the air pressure in the fuel bowl chamber for proper fuel delivery to the engine. The size of the plug is carefully established by engineering tests and the specified size for a given carbureter model must always be used to assure the proper operation of the carbureter on the engine. In some models, a calibrated fixed orifice is machined in the throttle body casting in place of the economizer plug.

To provide additional economy, in addition to the back suction economizer system, the carbureter provides for two adjusting needles, the low speed or idle adjusting needle and the load adjusting needle. These needles must not be interchanged. The idle adjusting needle head is brass plated and the load needle cadmium plated (gray color) to distinguish.

A throttle lever stop spring (Figure 1) is provided to prevent uneven running or "hunting" (governor opening and closing) when the load is released and the governor closes clear shut. Turn the throttle stop screw against the throttle lever stop spring until the "hunting" is corrected and idling is satisfactory. Normally there is  $\frac{1}{32}$ " clearance between the throttle stop screw and the throttle lever stop spring at fast idle.

While there are many variations produced by combining the types and sizes into a specific application, all Model DLTX Carbureters incorporate the same engineering principles and are alike from a functional standpoint.

## Service Instructions for Model DLTX Carburetors

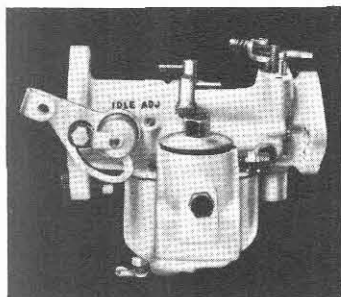

Type A—Cast Fuel Bowl

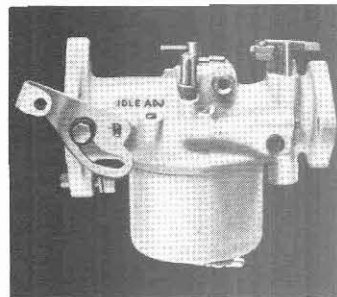

Type B—Stamped Fuel Bowl

The following procedure for service of DLTX carburetor models is for a complete overhaul. After removing carburetor from engine wash thoroughly with cleaning fluid, such as gasoline, to permit examination of external parts for damage. For type carburetor being serviced see illustrations above. Instructions apply to both types unless specified otherwise.

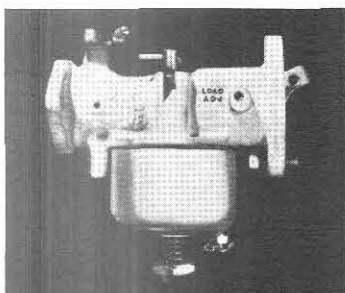

1—  
**Remove Bowl Retaining Nut, Gasket, and Nozzle Retaining Spring.**  
Separate Castings.

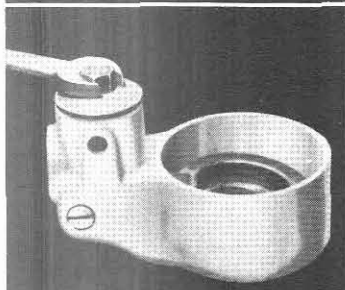

2—  
**Remove Fuel Strainer Assembly and Gasket.**  
Type A—  
Replace assembly if screen or threads are not in good condition.

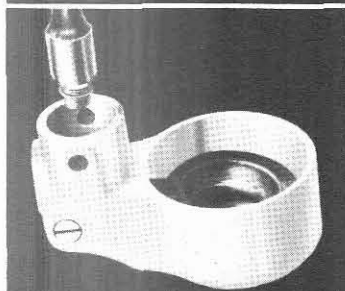

3—  
**Remove Float Valve Seat and Gasket.**  
Type A—  
Remove seat with Schebler Tool No. 725A.

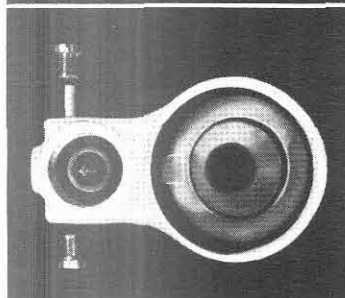

4—  
**Remove Float Lever Bearing Screws and Float Lever Pin.**  
Type A—  
Replace screws and pin if parts are worn.

5—  
**Remove Float and Lever Assembly & Float Valve.**  
Type A—  
Replace float valve and seat if valve is grooved or worn or seat damaged.

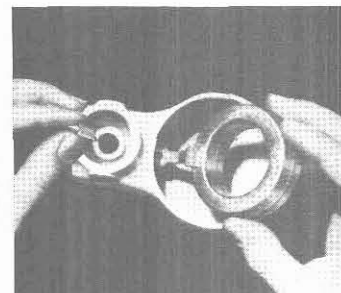

6—  
**Remove Float Valve, Float Valve Seat & Gasket.**  
Type B—  
Replace Float Valve and Seat if valve is grooved or worn or seat damaged.

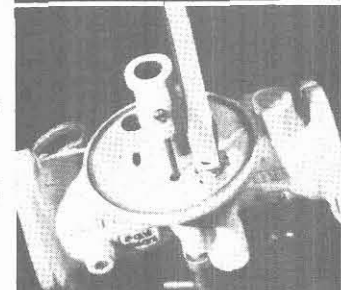

7—  
**Remove Load Adjusting Needle.**  
Replace needle if grooved or damaged.

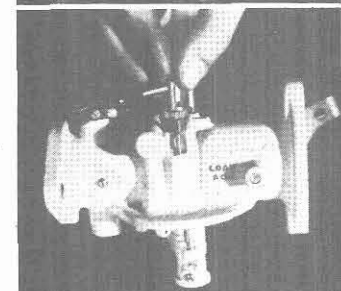

8—  
**Remove Idle Adjusting Needle.**  
Replace needle if grooved or damaged.

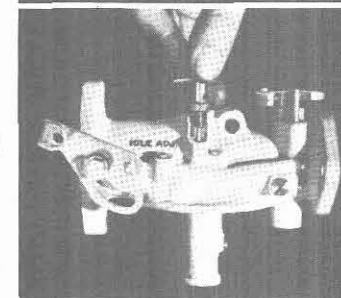



## Service Instructions for Model DLTX Carbureters

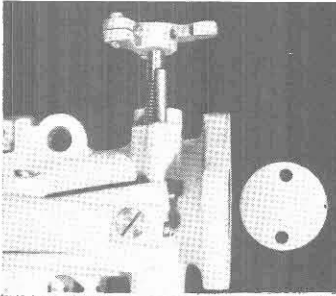

9—  
**Remove Throttle Valve Screws, Valve, & Throttle Shaft & Lever Assembly.**

NOTE: On some models it is necessary to first remove throttle lever from shaft before throttle valve can be removed. Replace throttle shaft if worn.

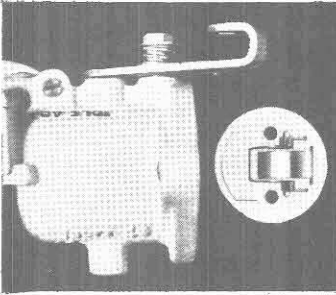

10—  
**Remove Choke Valve Screws and Valve.**

Do not remove choke shaft

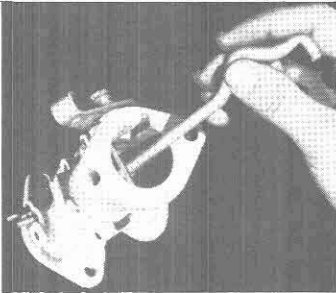

11—  
**Remove Nozzle.**

Insert flat end of Schebler Tool No. 2599 under choke shaft and force nozzle down as far as possible.

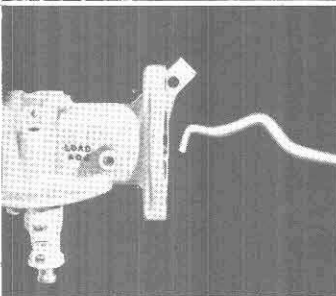

11A—  
 Insert bent end of tool over choke shaft and force nozzle out.

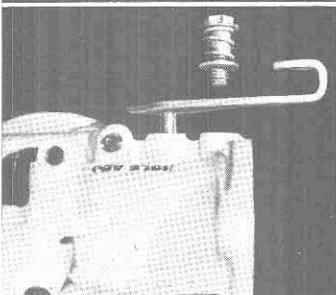

12—  
**Remove Choke Shaft and Lever Assembly.**

Replace shaft and lever assembly if shaft is worn.

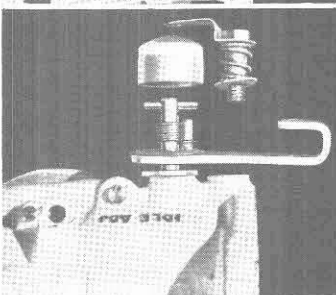

12A—  
**Remove Choke Shaft and Lever Assembly.**

Replace shaft and lever assembly if shaft is worn.

13—  
**Remove all Channel Plugs.**

### Throttle Shaft Bushing Repair

Procedure for replacing worn throttle shaft bushings.

14—  
**Remove Upper Throttle Shaft Bushing.**

Insert Schebler Tool No. 2603 & drive bushing out. NOTE: On Models DLTX-26 and DLTX-46 remove bushing with tool No. M-130.

15—  
**Remove Lower Shaft Bushing.**

Insert Schebler Tool No. 2603 through upper throttle shaft bushing boss and drive bushing out. On Models DLTX-26 and DLTX-46 use Tool No. M-131.

16—  
**Install Lower Shaft Bushing—Open End Bushing.**

Place new lower bushing on Tool No. M 132 and drive bushing in casting up to shoulder on tool.

16A—  
**Install Throttle Shaft Hole Plug.**

Drive plug flush with face of lower throttle shaft bushing boss.

16B—  
**Install Lower Shaft Bushing—Blind End Bushing.**

Drive bushing until flush with face of casting boss.

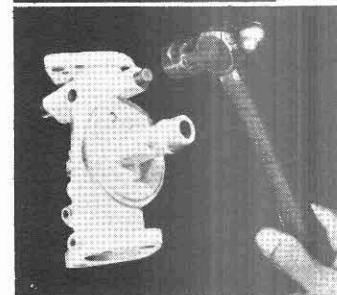
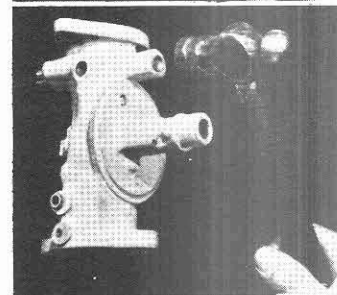
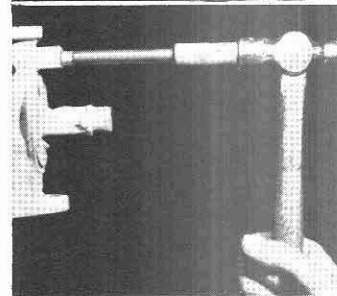
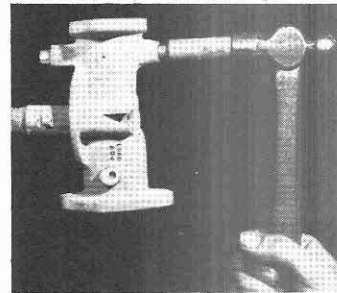
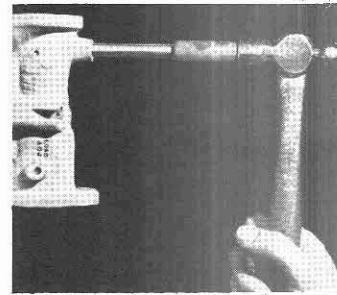
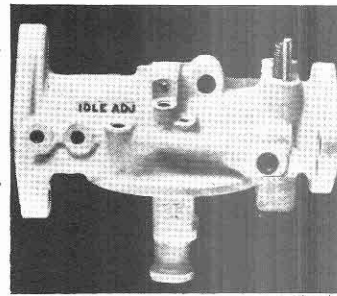



## Service Instructions for Model DLTX Carbureters

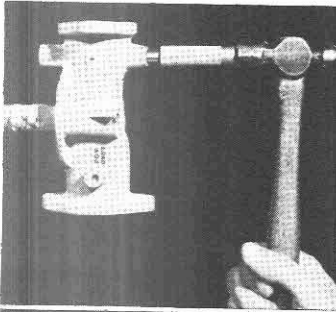

17—

### Install Upper Shaft Bushing.

Place new upper bushing on pilot of Schebler Tool No. 2604 and drive bushing into body until flush with top of casting boss. Use Tool No. M-129 for Models DLTX-26 and DLTX-46.

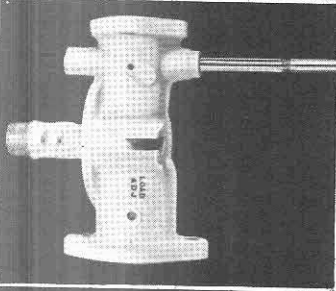

18—

### Ream Throttle Shaft Bushings.

If throttle shaft binds in bushings ream bushings with special reamer Schebler Tool No. 2606. Use reamer Tool No. M-128 for Models DLTX-26 and DLTX-46.

\* Assemble

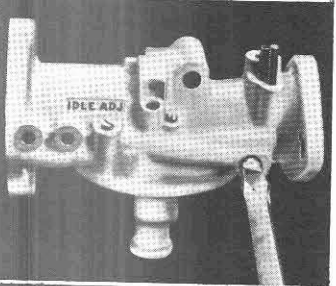

19—

### Install all Channel Plugs and Economizer Plug.

Install new economizer plug if plug is nicked or damaged.

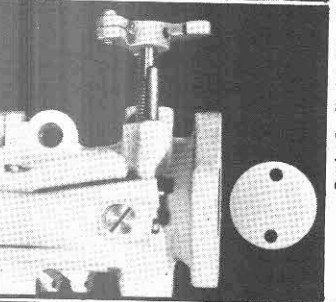

20—

### Install Throttle Shaft and Lever Assembly, Valve, and Screws.

Tap valve lightly to center in throttle bore. Tighten screws.

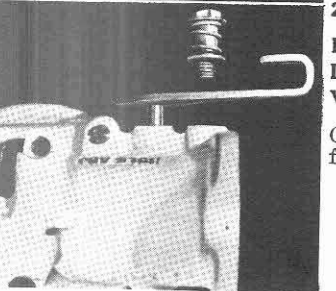

21—

### Install Choke Shaft and Lever Assembly, Choke Valve, and Screws.

Center valve in casting before tightening screws.

21A—

### Install Choke Assembly Parts, Choke, Valve, and Screws.

Before assembling dust cap attach the choke flex spring as shown in illustration below.

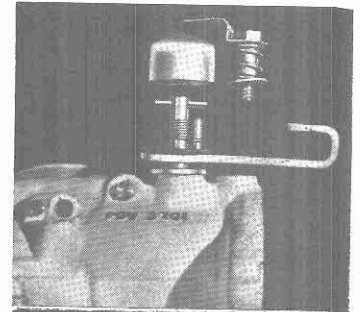

21B—

### Attach Choke Flex Spring

With choke valve in open position attach spring to pins on choke lever and shaft as shown.

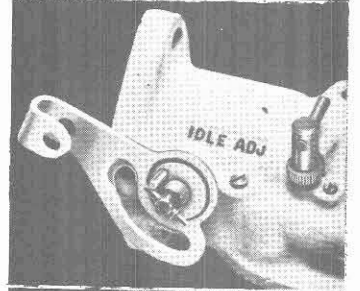

22—

### Install Idle Adjusting Needle.

Set approximately 1½ turns from seat for preliminary setting.

NOTE: Idle needle brass plated to distinguish.

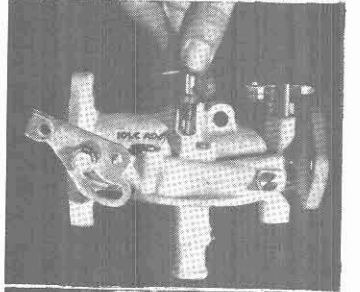

23—

### Install Load Adjusting Needle.

Set approximately 1 turn from seat for preliminary setting.

NOTE: Load needle cadmium plated (gray color) to distinguish.

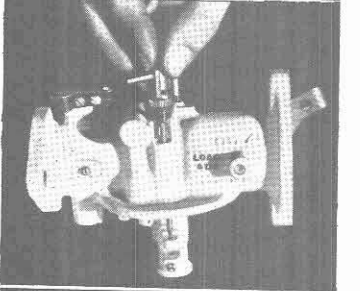

24—

### Install Nozzle.

Tap bottom of the nozzle lightly to seat in casting.

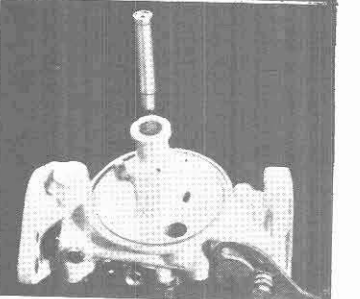

\* Before assembling carburetor, clean castings, channels, and parts with carburetor cleaning fluid and air under pressure. Make certain all small holes and channels are open and free from carbon and dirt. Do not use wire or small drills to clean out small holes as a slight change in size of these holes will affect the carburetor operation. Gum deposits not removed by carburetor cleaning fluid, clean with a lacquer thinner. To assure a successful overhaul always replace all worn or damaged parts and any parts that are questionable. Always use new gaskets.

## Service Instructions for Model DLTX Carbureters

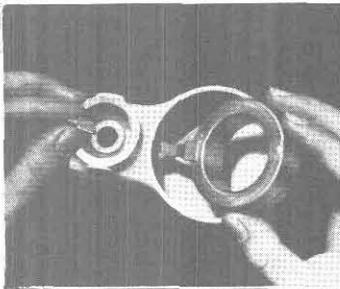

25—  
**Install Float and Lever Assembly & Float Valve.**

**TYPE A—**  
Before installing float submerge in pan of hot water. Replace if air bubbles are observed escaping from float.

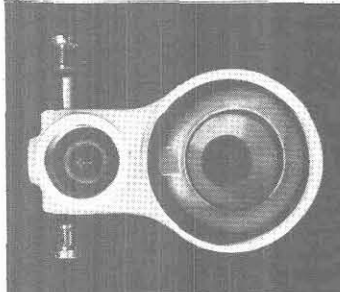

26—  
**Install Float Lever Pin and Float Lever Bearing Screws.**

**Type A—**

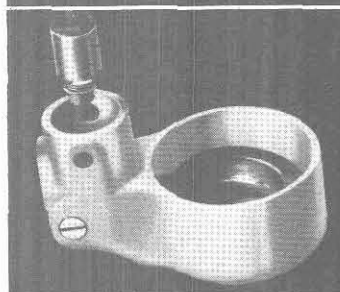

27—  
**Install Float Valve Seat and Gasket.**

**Type A—**  
Use new gasket. Examine action of float. Be sure there is no sticking between fingers on float lever and head of float valve.

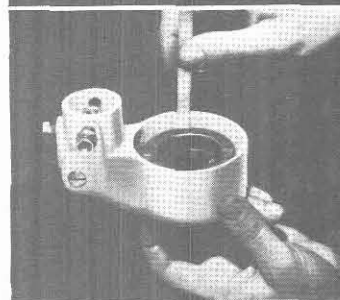

28—  
**Set Float Level.**  
**Type A—**  
Set float  $\frac{1}{2}$ " on models DLTX-3 to DLTX-63 inclusive.  
Set float  $\frac{3}{8}$ " on models DLTX-67 to DLTX-73 inclusive.  
Measure from top of fuel bowl to top of float. Use Schebler Tool No. 35 to bend float lever.

29—  
**Install Fuel Strainer Assembly.**

**Type A—**  
Always use a new strainer gasket.

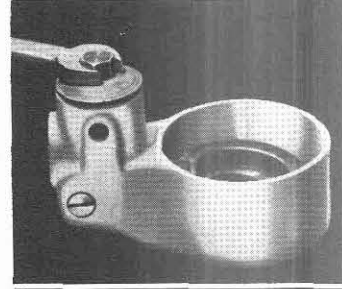

30—  
**Install Float Valve Seat, Gasket, and Float Valve.**

**Type B—**  
Use new gasket.

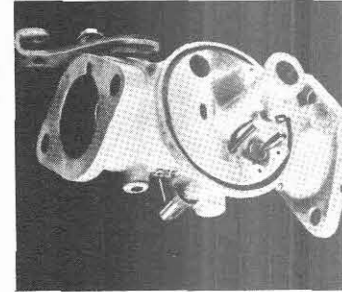

31—  
**Set Float Level.**  
**Type B—**

Before installing the float submerge in pan of hot water. Replace if air bubbles are observed escaping from float. Set the float  $\frac{3}{8}$ " from lower flange face to nearest edge of float.

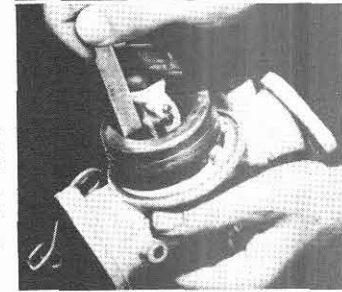

32—  
**Assemble Castings.**

Use new bowl gasket and bowl retaining nut gasket. Tighten bowl retaining nut securely.

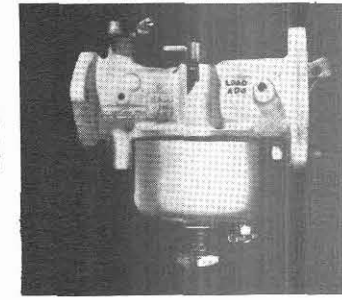

## ADJUSTMENT INSTRUCTIONS

### PRELIMINARY ADJUSTMENTS

Set speed control lever so that throttle valve is open slightly. Make certain that fuel supply to carbureter is open. Close choke valve. Start engine and partially release choke. After engine has been run sufficiently to bring up to operating temperature throughout, see that choke is returned to wide open position.

### IDLE ADJUSTMENT

Advance speed control lever to wide open throttle position which will be fast idle or governor controlled idle. Adjust idle adjusting needle until engine runs evenly.

**NOTE:** To enrich the idle mixture turn idle adjusting needle to the left or counter-clockwise.

### LOAD ADJUSTMENT

To secure maximum fuel economy with tractor pulling load turn the load adjusting needle to the right, or clockwise, until the power drops appreciably. Then turn the needle to the left, or counter-clockwise, until the engine picks up power and runs smoothly. Due to variations in temperature or fuels it may be necessary to richen up this mixture by backing out the power adjusting needle, a small amount at a time, until good acceleration is obtained.

If, when load is released, governor closes throttle clear shut, causing uneven running or "hunting," (governor opening and closing) turn the throttle stop screw against the throttle lever stop spring until the "hunting" is corrected and idling is satisfactory. Normally there is  $\frac{1}{8}$ " clearance between the throttle stop screw and the throttle lever stop spring at fast idle.

## Service Complaints

### IDLE—UNEVEN IN OPERATION

The idle construction used in Marvel-Schebler Tractor and Industrial Carbureters is the most positive and satisfactory of idle systems, because it is working under very high suction and the mixture flows through the small passages at very high velocities. It is necessary to bear in mind, however, that there are times when these small holes may become plugged with particles of dirt or lint, but very seldom. If idle trouble is experienced, first check the manifold to cylinder head gasket and the carbureter to manifold gasket for air leaks. At slow idle an engine requires only approximately 20 to 25 lbs. of air per hour, and a slight leak will result in a very erratic or rough idling engine.

Other causes for a rough idling engine are: uneven compression, caused by sticky or leaking valves; leaking valve seats; tappets with im-

proper clearances; leakage past pistons and rings; cylinder head gasket leaking; weak spark, or spark plug points not spaced correctly; ignition cable covering cracked and thus grounding spark, and cable not assembled properly in the distributor cap which causes corrosion and weak spark.

The spark timing of the engine is most important, and should also be checked very carefully and set exactly on the mark as called for in factory standard specifications. In fact, all of the above items must be checked very carefully to factory standards, and not just given a casual inspection with the common expression "Everything looks O.K." **You can KNOW definitely that the tractor is up to the standards set by the manufacturer.**

### POWER AND ECONOMY—LOW

Complaints are received from the field that the engine will not pull or develop its maximum horsepower, or that it develops good power, but uses far too much fuel. Too often a service man will at once change the carbureter to correct these complaints, but by so doing he may not be successful in overcoming the difficulty.

It must be clearly understood by all servicemen that when a new engine is designed and developed the management first decides what horsepower they want this engine to produce at a definite rated speed. The engineering department develops the new engine to pull the required horsepower. In the design there are certain fixed dimensions that never change. For instance, the bore and stroke, the displacement, compression ratio, diameter of valves, lift of valves, diameter of intake passage. The carbureter engineer works out the diameter of throttle

bore, venturi size, and provides for means of adjusting and regulating the power fuel mixture ratio, as well as the idle. Now, in service, consider, that the compression, ignition, and timing have been checked and found to be 100% in this engine. If the air intake temperature and the water temperature is held constant, then the only variable we have that affects maximum horsepower is the fuel mixture ratio.

If compression, ignition, and timing, which are variable, are first properly checked by a service man and set to factory specifications, very little difficulty will be experienced in adjusting the carbureter to give the maximum horsepower and economy.

A great deal has been said regarding the importance of engine tune-up and the reasons for service men being exact in their service work on engines. The reasons why a carbureter may not

function properly when everything else has been checked and set to factory standards will now be covered.

With the present type carbureter construction used on Marvel-Schebler tractor and industrial carbureters, not very much can go wrong with the possible exception that it may foul with dirt. There are only two places that are subject to wear—the throttle shaft and bushings and the float valve and seat. The wear on the throttle shaft and bushings, and resultant air leak therefrom results in a lean idle, and to compensate for the air leak more fuel must be turned on for idle. Wear on the float valve and seat results in a high fuel level in the fuel bowl and flooding trouble. Both faults can be easily observed by the service man, and corrected by replacing worn parts with new ones. The proper function-

ing of the carbureter is obtained by a series of holes drilled to exact size and location, which do not wear or change location in service. It must be realized that if the carbureter worked correctly at first, when passed by the inspectors at the tractor factory, it will always function the same, provided these passages are all free from dirt.

On a carbureter complaint from the field, the only thing a service man can do to the carbureter is to disassemble it. BE SURE that the passages are open and free from dirt, that there is no wear on the throttle shaft and bushings, that float valve and seat are O.K., that the float height is correct, and that a good air-tight seal exists around the bowl gasket. If such carbureter service does not correct the complaints, a complete check of the engine must again be made.

# Marvel-Schebler Carbureter FLOAT SETTINGS

To check the float setting, the casting must be held in an inverted position so that the float lever is in contact with the float valve and the float valve seated.

Carbureter Model	Factory Setting	Where to Measure
DLTX-26 and 46.....	$\frac{3}{16}$ "	From the bottom of the nozzle boss to the nearest surface of the float.
DLTX-67, 71, 72, 73.....	$\frac{3}{8}$ "	From the bowl gasket to the nearest surface of the float.
All other DLTX (except duals) (Cork or Metal Float).....	$\frac{1}{2}$ "	From the bowl gasket to the nearest surface of the float.
Duplex DLTX.....	$\frac{3}{4}$ "	From bowl gasket seat in casting to bottom of float.
"H".....	$\frac{1}{16}$ " to $\frac{3}{32}$ "	From the gasket to the top of the float.
"MA" (All except MA-4-5).....	$\frac{1}{2}$ "	From the top of the float to the gasket.
MA-4-5.....	$\frac{1}{16}$ "	From the top of the float to the gasket.
"N".....	$1\frac{3}{4}$ "	From the bowl cover face to the bottom of the float.
"NNF".....	$\frac{1}{8}$ "	From top of float to flange gasket.
"TCX".....	$1\frac{5}{16}$ "	From upper bowl gasket to bottom of float.
"TRX".....	$1\frac{7}{8}$ "	From the gasket to the bottom of the float.
"TSX" $\frac{7}{8}$ ", 1", 1 $\frac{1}{4}$ ".....	$\frac{1}{4}$ "	From the gasket to the nearest surface of the float.
"TSV".....	$\frac{1}{4}$ "	From the gasket to the nearest surface of the float.
"TTX".....	2"	From the face of the flange to the bottom of the float.
"VD".....	$\frac{5}{16}$ "	From the gasket to the end of float furthest from hinge pin.
"VH" $\frac{5}{8}$ ".....	$\frac{1}{2}$ "	From the nozzle boss to the end of the float furthest from hinge pin.
"VH" 1".....	$\frac{3}{16}$ "	From the gasket flange face to the bottom of the float.

NOTE: Changing the float setting from our standard in an effort to improve the operation of the carbureter or in an effort to prevent flooding, will only result in faulty carbureter operation.



# **SPECIAL SERVICE NOTE**

## **How to Give Your Engines Longer Life!**

A loose throttle shaft and worn packings will allow coarse, highly abrasive dirt to be pulled into the engine. It has been proved by actual test, that under extreme dust conditions, such as encountered by off-the-road-equipment, it is possible to wear the cylinder walls down one thousandths of an inch in 50 hours of operation as a result of leakage around a worn throttle shaft.

Make sure on all engine overhaul and tune up jobs that the carbureter is removed, cleaned and all worn parts replaced.

Remember! it's not the air which is drawn into the engine around worn shafts which wears out rings, valves and cylinder walls, it's the dust and dirt in the air.

**Dirt Is Engine Enemy No. 1**